

intec | colorflare

NEW
CF1200
RANGE

Add premium decorative effects to printed sheets



- Metallic foiling
- Holographic films
- Lamination

THE MAGIC STARTS HERE

 10m P/MIN	 2,500 SRA4 P/HOUR	 BURST SEPARATOR WHEEL	 120 ~ 400 gm ²
 FORMATS Min: 210 x 297mm Max: 380 x 1219mm	 MULTI FX	 INTEGRATED COMPRESSOR	 HOT ROLLER



Easily add decorative creativity to printed sheets with ColorFlare

Laminates | Foils | Holographics

- NEW Even more pneumatic pressure
- NEW Ships with premium finish flaring assembly
- NEW Level, +5° or +10° inclined delivery table
- NEW Lamination pull roll control
- Advanced dual process for lamination and foil flaring technologies for digital applications
- Multiple jobs and flaring effects are possible with just 1 machine
- No need to have traditional UV coating for diverse effects

The upgraded Intec ColorFlare is a compact and environmentally-friendly, dual laminator and foil-flaring device, designed to offer an in-house decorative effects solution for short-run, on demand digital applications, as well as lamination for traditional litho output too! With the ability to laminate and foil-flare straight out of the box, this high-quality production unit will soon start earning its keep, and *you*, a great reputation!

Intec ColorFlare: Raising ordinary print work to 'extra-ordinary'. ColorFlare has been developed to meet specific print-finishing requirements and built to exacting technical standards – with fully controllable pressure and heat processes, devised to deliver optimum results with today's digital print output.

Both lamination and flaring-film rolls are available in a choice of widths and lengths to deliver great value and cost-effective production – particularly when using the CF1200L model with its extended input table for banners and long media.

A game-changing finishing device
Faultless lamination. Class-leading lamination for the commercial printer. Using state-of-the-art technology, combined with integrated pneumatic pressure, the Intec ColorFlare delivers superior bonding and faster production times – compared to standard systems. In addition, the fully-adjustable heat and pressure combinations enable a wider range of laminates to be used with printed media, including the traditionally troublesome digital print output!

Stunning foil-flaring. For today's printers who demand stunning results with that extra 'wow' factor – the ColorFlare delivers *more* than just class-leading lamination. Metallic, coloured, patterned or holographic

Wedding invitation 2 x spot metallic foil flaring = Business card spot gloss lamination with metallic red foil flaring - Menu spot metallic foiling and holographic lamination

style flaring foils can be added to digitally printed materials in either spot or flood treatments. This decorative effect is known as 'flaring', and traditionally, costly custom dies would be required to create these effects. However, ColorFlare can deliver instant and affordable results - and with upgraded pneumatic pressure, an even wider choice of media is now suitable for great results! Even further-advanced effects can be delivered by combining Intec special corona-treated laminates with Intec decorative effect flaring foils. Clever compound treatments deliver ultra-premium results - all from one compact device!

Unique differences
Visual and tactile decoration. Intec has a range of specially formulated digital laminates, each featuring an advanced corona treatment,

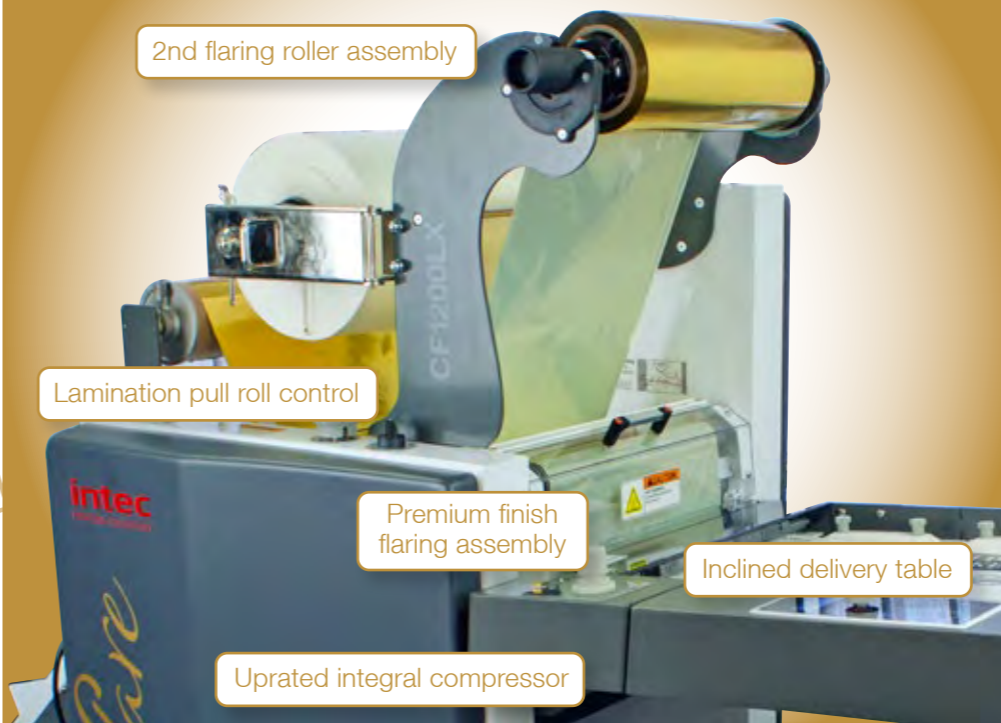

Maximise output with the flagship CF1200LX

2nd flaring roller assembly
 This additional arm and roller assembly allows both laminates and metallic foils to be loaded simultaneously - reducing set up times and enabling a much faster switch between media. Furthermore, this unique additional flaring roller assembly, enables dual - even multiple - metallic rolls, to be loaded for foiling of multiple metallics - all at the same time!

Premium finish flaring assembly
 This 'accessory' now ships as standard with the CF1200L and LX models and is easily installed within moments. It is utilised when a superior mirror finish foil is desired. The super-soft surface of the roller gently smooths the foil into a perfectly flat condition, just at the point of application.



Metallic spot foil flaring - choice of finishes - makes your print ooze premium quality



Create the 'WOW' effect with high gloss lamination to make your print 'sing'



Carbon fibre holographic lamination adds a touch of mechanical techno-class

which enables *subsequent overprinting* through digital devices. This provides the opportunity to further enhance printed materials with additional decorative effects when using a combination of lamination and foil flaring. No ordinary laminating device can achieve *anything like* these unique and superb results!

Speedy and accurate production
 Turnaround times and waste are further minimised with the ColorFlare unique 'burst separation' system. The laminating film is micro-perforated on the edge by the robust marking device and then separated by the pneumatic burst roller. This easily separates the laminated sheets prior to the actual edge of the media, leaving clean and square datum edges from which to measure, cut, fold or guillotine. Other devices tend to need time-consuming and untrue manual separation.

Premium effects gain premium profits
 The flexibility to create and control stunning effects from just one compact device will lift ordinary print work to the level of extra-ordinary – and offers an even greater return on investment.



The new inclined feed table can be set level, or at 5° or 10° to aid semi-automatic feeding, which helps to increase productivity



The new pull roll control, enables improved foil flaring results by allowing the user to disengage the lamination pull roller when performing foil flaring



Easy-to-use touch panel provides instant digital control, including sheet size, speed and temperature for laminates and flaring / decorative effect films



Premium finish flaring assembly helps achieve a superior mirror finish when foil flaring large areas. Now comes as standard with CF1200L and LX models



Even more pneumatic pressure with CF1200 models, offering wider choice of media for stunning metallic foil flaring results



Automatic burst separating system separates sheets and delivers a clean datum edge from which to easily cut or guillotine

Premium decorative effects for digital solutions

colorflare



ColorFlare printer compatibility guide*

intec

Intec ColorFlare has been developed to work with the world's top digital printer manufacturers.



Canon



Kodak



RICOH
imagine. change.



*Call for confirmation of model compatibility

Technical specifications*	
Laminating speed	1.5m/min ~ 10m/min
Base substrate thickness	120 ~ 400gm ²
Front roller diameter	Top: high glossy chrome 100mm Bottom: silicon 80mm
Rear roller diameter	Silicon 55mm
Power requirement	AC 220~240V, 50/60Hz, 12A
Power consumption	2.8kw
Warm-up time	5 minutes
Heating system	Infrared heater
Laminating temperature	Maximum 150°C
Temperature control	Capacitive touch screen
Speed control	Capacitive touch screen
Display system	LCD Panel
Roller pressure	Pneumatic cylinder
Film core size	77mm (3") / Dual - 58mm, 50mm
Air compressor	100 psi maximum pressure, 3.2 CFM open flow (50 Hz)
Temperature sensing method	Thermo-couple inserted in the roller shell
Net weight CF1200L	265kg Net 290kg Packed
Net weight CF1200LX	274kg Net 299kg Packed
Dimensions (Unpacked)	
Model	W x L x H
CF1200L	710 x 2010 x 1350mm
CF1200LX	710 x 2010 x 1475mm
Paper size	
Maximum	- Minimum
CF1200L	380 x 1219mm - 180 x 210mm
CF1200LX	380 x 1219mm - 180 x 210mm

ColorFlare footprint

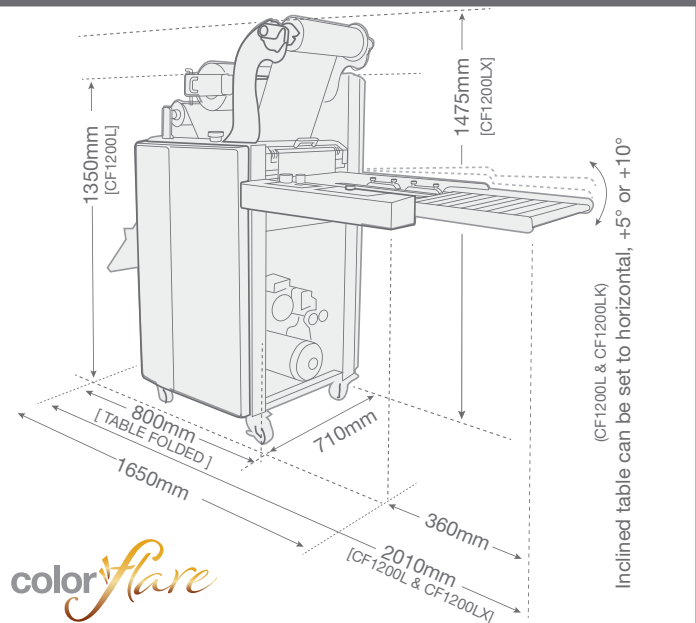

CF1200L	CF1200LX
+ Extended, inclined table + Premium finish flaring assembly	+ Extended, inclined table + Premium finish flaring assembly + 2nd Flaring roller assembly

A growing range of consumables...*

Lamination films
Various finishes including: gloss, matt and soft touch, for litho and digital print. Digital laminates are corona-treated for subsequent over-printing.

Foil flaring films
Available in a growing range of colours including: gold, silver, rose gold, copper, red, green, blue, violet, black, white and clear gloss. All can be applied direct to print.

Holographic flaring films
Such as: sparkle, milky way, crystal, carbon fibre... Perfect for adding premium effects to print.
*See consumables support sheet.

